

surprising, as it is now clear that strong metal-metal bonding persists in the low-lying $\delta\delta^*$ and $\delta\pi^*$ excited states. This is evidenced by the sharp vibronic structure that is built on $\delta \rightarrow \delta^*$ and $\delta \rightarrow \pi^*$ systems and the fact that the a_{1g} metal-metal stretching vibration is diminished by only 10–20% in the excited states in question. Rapid conversion of upper metal-localized excited states to these inactive ones greatly reduces the probability of metal-metal bond cleavage. It is possible that a transition to a $\sigma\sigma^*$ state might result in bond cleavage; however, this will be difficult to test. Recall that a band attributable to $\sigma \rightarrow \sigma^*$ has never been observed in the electronic spectra of d^4 - d^4 complexes, and it is presumed to lie at wavelengths shorter than 200 nm.

Concluding Remarks

In this Account we have emphasized the role that electronic spectroscopic and photochemical studies have played in the development of our present understanding of the nature of quadruple metal-metal bonds. The results have established that the lowest metal-localized electronic transitions in prototypal complexes ($\text{Re}_2\text{X}_8^{2-}$, $\text{Mo}_2\text{X}_8^{4-}$, $\text{Mo}_2(\text{SO}_4)_4^{4-}$, $\text{Mo}_2(\text{O}_2\text{CR})_4$) are derived from

$\delta \rightarrow \delta^*$, $\delta \rightarrow \pi^*$, and $\pi \rightarrow \delta^*$ transitions, with the energy order $\delta \rightarrow \delta^* < \delta \rightarrow \pi^*$ in all cases except $\text{Mo}_2(\text{O}_2\text{CR})_4$. The $\delta\delta^*$ singlet states lie about $14\,000\text{ cm}^{-1}$ (40 kcal/mol) above the ground state in the binuclear $\text{Re}(\text{III})$ complexes, and at about $19\,000\text{ cm}^{-1}$ (54 kcal/mol) in $\text{Mo}_2\text{Cl}_8^{4-}$, $\text{Mo}_2\text{Br}_8^{4-}$,⁴¹ and $\text{Mo}_2(\text{SO}_4)_4^{4-}$. The $\delta\pi^*$ singlet states lie about $17\,000\text{ cm}^{-1}$ (49 kcal/mol) above the ground state in $\text{Re}_2\text{X}_8^{2-}$ and at about $22\,000\text{ cm}^{-1}$ (63 kcal/mol) in several $\text{Mo}_2(\text{O}_2\text{CR})_4$ complexes. Analysis of the vibronic structure of the $\delta \rightarrow \delta^*$ and $\delta \rightarrow \pi^*$ bands has shown that the metal-metal bond strengths, which are relatively large in the ground states (>100 kcal/mol), are not weakened appreciably (<20%) in $\delta\delta^*$ and $\delta\pi^*$ excited states. Photoactivity is not associated with either of these lower excited states in the complexes examined to date.

It is a special pleasure to acknowledge the many contributions Dr. Charles D. Cowman made in the early stages of this research. We also thank Dr. R. J. H. Clark and Professors F. A. Cotton, W. A. Goddard III, D. S. Martin, Jr., J. G. Norman, Jr., and E. I. Solomon for helpful discussions and for sending us preprints of their works. Our work was supported by the National Science Foundation. This Account is Contribution No. 5616 from the Arthur Amos Noyes Laboratory.

Phosphorylation by Means of Cyclic Enediol Phosphates¹

FAUSTO RAMIREZ* and JAMES F. MARECEK

Department of Chemistry, State University of New York at Stony Brook, Stony Brook, New York 11794

Received August 29, 1977

Several classes of important biological compounds, for example the nucleic acids and the phospholipids, are diesters of phosphoric acid. Consequently the nonenzymatic conversion of two alcohols into a phosphodiester (eq 1) as a route to these compounds has attracted the attention of the organic chemist for many years.²

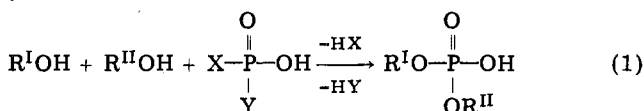

The nucleic acids are linear polymers in which pentoses of adjacent nucleoside units are interconnected by 3'→5' phosphodiester bridges (1). The first synthesis of a dinucleoside phosphate containing the natural 3'→5' internucleotide bond was carried out by Michelson and Todd³ in 1955, and since that time much effort has been expended in improving the synthetic methodology.⁴ Despite recent advances, there still remains a need for more versatile phosphorylation procedures.

Fausto Ramirez has been Professor of Chemistry at the State University of New York (Stony Brook) since its foundation in 1959. He was born in Zulueta, Cuba, attended the University of Havana, and received a Ph.D. degree from the University of Michigan in 1950, working with W. E. Bachmann. He received further training under A. Burger at the University of Virginia. His research has dealt with the chemistry of phosphorus.

James F. Marecek is an Associate Research Director at Stony Brook. He was born in Berwyn, Ill., and received a Ph.D. degree from Case Western Reserve University in 1971, working with Dean L. Griffith.

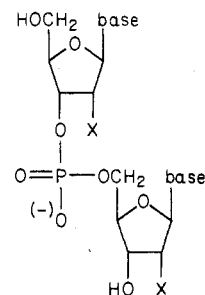

1, X = H or OH

A second important class of phosphodiesters are the phospholipids (see Chart I). Found in biological membranes, they are composed of *O*-acyl or *N*-acyl derivatives of three types of polyols: glycerol, di-

(1) Supported by grants from the National Institutes of Health (GM 20672) and the National Science Foundation (MPS73-04944 and CHE76-16785).

(2) (a) H. G. Khorana, "Some Recent Developments in the Chemistry of Phosphate Esters of Biological Interest", Wiley, New York, N.Y., 1961; (b) D. M. Brown, *Adv. Org. Chem.*, 3, 75 (1963); (c) F. Cramer in "Newer Methods of Preparative Organic Chemistry", Vol. 3, W. Forest, Ed., Academic Press, New York, N.Y. 1964; (d) K. Sasse in "Methoden der Organischen Chemie", Vol. 12, Part 2, E. Muller, Ed., Georg Thieme Verlag, 1964; (e) V. M. Clark, D. W. Hutchinson and D. E. Wilson, *Angew. Chem., Int. Ed. Engl.*, 4, 240 (1965).

(3) A. M. Michelson and A. R. Todd, *J. Chem. Soc.*, 2632 (1955).

(4) (a) F. Cramer, *Angew. Chem., Int. Ed., Engl.*, 5, 173 (1966); (b) K. L. Agarwal, A. Yamazaki, P. J. Cashion, and H. G. Khorana, *Angew. Chem., Int. Ed. Engl.*, 11, 451 (1972); (c) R. J. Zhadanov and S. M. Zhenodorova, *Synthesis*, 222 (1975); (d) V. Amarnath and A. B. Broom, *Chem. Rev.*, 77, 183 (1977); (e) M. Ikehara, *Acc. Chem. Res.*, 7, 92 (1974).

Chart I
Phospholipid Components

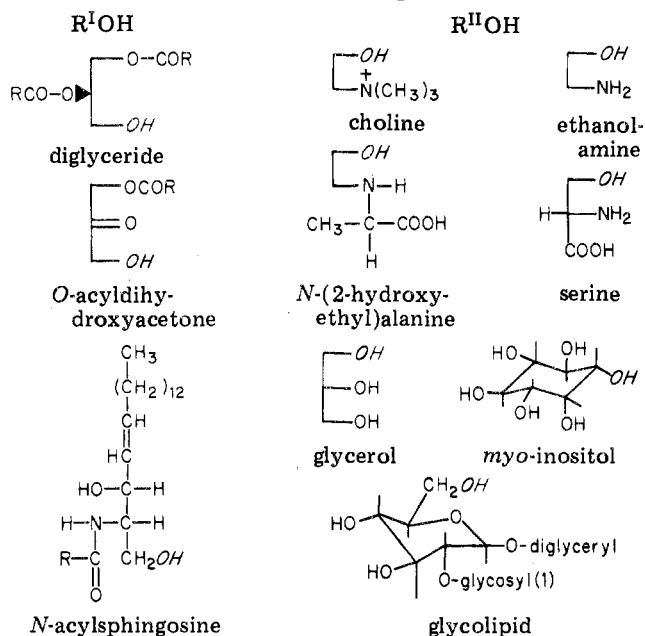

hydroxyacetone, and sphingosine. Each of these fatty acid esters or amides (the $R^I OH$ component) is linked by a phosphodiester bond to other alcohols (the $R^{II} OH$ component). In spite of the complexity of membrane constituents, very few basic structures are represented in the $R^{II} OH$ moiety, and the wide variety of properties required for membrane function are achieved by appropriate substitutions on these building blocks. For example, glycerol may carry acyl, α -aminoacyl, phosphoryl, D-glucosamine, or polysaccharide residues. *myo*-Inositol may carry one or more phosphoryl groups, or a D-mannose glycoside. The maximum degree of complexity is reached when a glycolipid itself plays the role of the $R^{II} OH$ component.

Evidently, the challenge in this field stems from the polyfunctionality and the lability of the substrates, $R^I OH$ and $R^{II} OH$. Moreover, there are inherent difficulties in the preparation of an unsymmetrical phosphodiester free from the symmetrical byproducts, $(R^I O)_2 P(O)OH$ and $(R^{II} O)_2 P(O)OH$. This problem can be approached in terms of the sequence in which the two P-O bonds of the diester are created since either one alcohol or the other can be added first. The optimum strategy for a particular compound will depend mainly on the compatibility between the phosphorylating reagents and the substrates, including any *protecting groups* placed on the latter to avoid side reactions.

This Account discusses recent contributions to the methodology of phosphodiester synthesis from this laboratory. Our earlier results have been summarized elsewhere.⁵ Reviews⁶ dealing with stable oxyphosphoranes, i.e., with oxygen-containing P(5) compounds,⁷ also provide background for the present work.

Previous Phosphodiester Syntheses. Phosphodiesters have been prepared by two basically different

routes: (i) direct methods, which lead to the acidic function $>P(O)OH$,⁸⁻¹³ (ii) indirect methods, which generate an intermediate $>P(O)Z$ subsequently transformed into the acidic function.¹⁴⁻²⁰ The indirect methods utilize a *blocking group*, Z, to prevent side reactions at phosphorus. Usually, the intermediate is a phosphotriester, $(R^I O)(R^{II} O)P(O)OZ$, and the de-blocking step may involve a P-OZ or a PO-Z bond cleavage. The distinction is significant because P-OZ bond fission commonly involves displacement at phosphorus, which could also disrupt the desired phosphodiester group producing, e.g., $(HO)(R^{II} O)P(O)OZ$. Evidently, this particular problem does not arise in PO-Z bond fission.

In principle, a single reagent of type $XYP(O)OH$ or $XYP(O)OZ$ should suffice to create both P-O bonds, but in practice *activating reagents* are often introduced to achieve the necessary differences in reaction rates in the two phosphorylation steps. The activating reagents combine in situ with the phosphorus-containing species to form the reactive intermediate. A variety of techniques have been introduced to generate unsymmetrical phosphodiesters by the direct and indirect methods.⁸⁻²⁰

Derivatives of the Cyclic Enediol Phosphoryl (CEP⁷) Group as Phosphorylating Reagents. In 1962 we discovered²¹ that dimethyl 3-oxo-2-butyl phosphate undergoes hydroxide ion catalyzed hydrolysis over 2×10^6 times faster than trimethyl phosphate (eq 2). The hydrolysis yields predominantly dimethyl

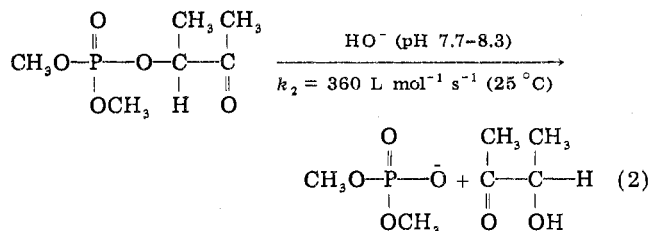

phosphate and the α -ketol, although ca. 5% of methanol is also produced.²²

To explain these results we suggested the formation of oxyphosphorane intermediates (in contradistinction to transition states) in this type of reaction.²³⁻²⁵ The

(5) F. Ramirez, J. F. Marecek, and I. Ugi, *J. Am. Chem. Soc.*, **97**, 3809 (1975).

(6) F. Ramirez, *Acc. Chem. Res.*, **1**, 168 (1968).

(7) P(4), P(5), P(6) = four-, five-, six-coordinate phosphorus; Acn = 3-oxo-2-butyl.

(8) T. M. Jacob and H. G. Khorana, *J. Am. Chem. Soc.*, **86**, 1630 (1964).

(9) T. Mukaiyama and M. Hashimoto, *Bull. Chem. Soc. Jpn.*, **44**, 196 (1971).

(10) M. Rubinstein and A. Patchornik, *Tetrahedron*, **31**, 2107 (1975).

(11) J. G. Moffatt and H. G. Khorana, *J. Am. Chem. Soc.*, **79**, 3741 (1957).

(12) T. A. Khwaja, C. B. Reese, and J. C. M. Stewart, *J. Chem. Soc. C*, 2092 (1970).

(13) N. T. Thuong and P. Chabrier, *Bull. Soc. Chim. Fr.*, 2083 (1975).

(14) Y. Mushioka, T. Hata, and T. Mukaiyama, *Bull. Chem. Soc. Jpn.*, **44**, 232 (1971).

(15) R. L. Letsinger, K. K. Ogilvie, and P. S. Miller, *J. Am. Chem. Soc.*, **91**, 3360 (1969).

(16) A. Francke, K. H. Scheib, and F. Eckstein, *Chem. Ber.*, **101**, 2998 (1968).

(17) J. H. Van Boom, P. M. J. Burgess, R. Crea, W. C. M. Luyten, A. B. J. Vink, and C. B. Reese, *Tetrahedron*, **31**, 2953 (1975).

(18) N. Katagiri, K. Itakura, and S. A. Narang, *J. Am. Chem. Soc.*, **97**, 7332 (1975).

(19) (a) R. L. Letsinger and W. B. Lunsford, *J. Am. Chem. Soc.*, **98**, 3655 (1976); (b) R. L. Letsinger and J. L. Finnan, *ibid.*, **97**, 7197 (1975).

(20) K. K. Ogilvie, S. J. Beaucage, N. Theriault, and D. W. Entevistle, *J. Am. Chem. Soc.*, **99**, 1277 (1977).

(21) F. Ramirez, B. Hansen, and N. B. Desai, *J. Am. Chem. Soc.*, **84**, 4588 (1962).

(22) D. S. Frank and D. Usher, *J. Am. Chem. Soc.*, **89**, 6360 (1967).

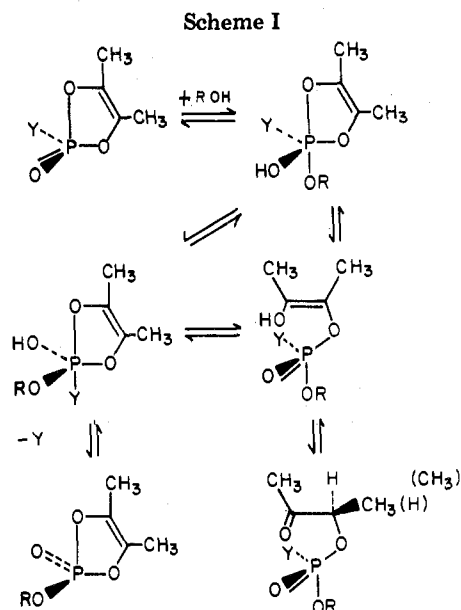

kinetic expression which results from this mechanism is extremely complicated²⁶ and requires many assumptions and approximations in order to yield correlations between reaction rates, product ratios, and structure of the alkyl groups in the substrate. However, the significant point is that the deblocking step is assumed to involve C-O as well as P-O bond cleavage.

The development of a general phosphodiester synthesis based on the α -ketol as blocking group takes the form of a three-step procedure (eq 3). Step 1 is the

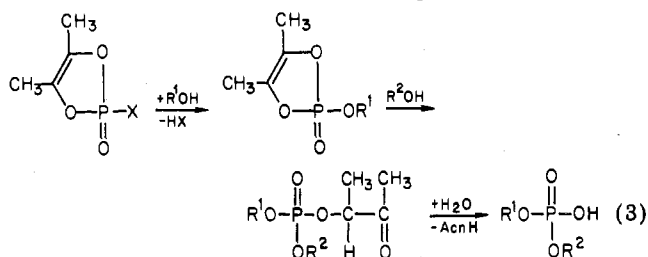

phosphorylation of the first alcohol, R^1OH , by a $CEP-X$ reagent to give a cyclic triester, $CEP-OR^1$. Step 2 is the phosphorylation of the second alcohol, R^2OH , by $CEP-OR^1$ to give a dialkyl 3-oxo-2-butyl phosphate. Step 3 is the hydrolysis of the α -ketol triester to the phosphodiester. This overall strategy can be implemented in several ways: (i) one-step synthesis, where no intermediate is isolated in the conversion of R^1OH into the diester; (ii) two-step synthesis, where the acyclic triester is isolated and then submitted to the deblocking step; (iii) three-step synthesis, where both the cyclic and the acyclic triesters are isolated.

Compounds with the CEP group are extremely reactive, being examples of highly strained five-membered cyclic phosphates.^{27,28} In mechanistic terms (Scheme

I) the formation of trigonal-bipyramidal P(5) by addition of a nucleophile to the cyclic phosphate involves relatively small additional bond angle deformations beyond those already present in the phosphate. Cyclic phosphates lose stability relative to the corresponding acyclic compounds.²⁷ The reverse is true for oxyphosphoranes,^{6,28} since there is a great deal of intramolecular crowding in the latter and the decrease in the crowding resulting from the introduction of nearly planar rings outweighs the ring strain associated with bond angle deformations. The characteristic behavior of five-membered cyclic phosphates is, therefore, determined by their ability to form oxyphosphorane intermediates and by the relative effects of ring strain vs. intramolecular crowding in tetracoordinate phosphorus [P(4)] and pentacoordinate phosphorus [P(5)] systems.

The occurrence of ring retention or of ring opening in substitutions at CEP derivatives depends mainly on the ability of the substituent Y to move to an apical position of the trigonal-bipyramidal P(5) intermediate and on the nucleofugicity of Y. Group Y can be chosen ($Y = X$) in such a way that the substitution occurs with virtually complete ring retention. However, when $Y = OR$, as in $CEP-OR$, the goal of achieving substitution with 100% ring opening is not always fully realized. Substitution with ring retention in the second step of the synthesis is undesirable because this transesterification may lead to symmetrical triesters: $CEP-OR^1 + R^2OH \rightarrow CEP-OR^2 + R^1OH$; $R^1OH + CEP-OR^1 \rightarrow (R^1O)_2P(O)OAcn$; $R^2OH + CEP-OR^2 \rightarrow (R^2O)_2P(O)OAcn$.

The successful application of $CEP-X$ in synthesis depends on the remarkably effective catalysis of the reaction: $CEP-OR^1 + R^2OH \rightarrow (R^1O)(R^2O)P(O)OAcn$ by imidazole,²⁹ triethylamine,²⁹ phenoxide ion,³⁰ and acetate ion³¹ in aprotic solvents. The catalysis is beneficial for three reasons. (i) It permits the phosphorylation of relatively bulky alcohols, whose uncatalyzed reaction rates are impractically slow. (ii) It allows a wider use of aprotic solvents, since rates in these phosphorylations are solvent dependent, and become too slow in relatively more polar media in the absence of catalyst. (iii) It reduces the extent of transesterification and hence decreases the formation of symmetrical byproducts; i.e., the catalysts influence the ratio of ring opening to ring retention, as well as the reaction rate. Moreover, triethylamine increases the *selectivity* with which $CEP-OR^1$ phosphorylates primary alcohols in the presence of unprotected secondary alcohols. The relatively bulky tertiary amine increases the phosphorylation rate of primary but not of secondary alcohols. Imidazole increases the phosphorylation rate of both types of alcohols and has no significant effect on selectivity.

These effects have been rationalized with the aid of the hypothesis²⁹⁻³¹ that nucleophilic catalysis of phosphorylation is exerted via P(6) intermediates (eq 4, using the catalyst $ArO-M^+$ as illustration). The existing data support the conclusion that the step P(5)

(23) For a compilation of basic papers on the *oxyphosphorane intermediate hypothesis* in nucleophilic displacements at P(4), see ref 24. The direct observation of a hydroxyphosphorane in equilibrium with a phosphate ester has been reported (ref 25).

(24) W. E. McEwen and K. D. Berlin, Ed., "Organophosphorus Stereochemistry", Dowden, Hutchinson and Ross, Stroudsburg, Pa., 1975.

(25) F. Ramirez, M. Nowakowski, and J. F. Marecek, *J. Am. Chem. Soc.*, **99**, 4515 (1977).

(26) P. Gillespie, F. Ramirez, I. Ugi, and D. Marquarding, *Angew. Chem., Int. Ed. Engl.*, **12**, 91 (1973).

(27) (a) P. C. Haake and F. H. Westheimer, *J. Am. Chem. Soc.*, **83**, 1102 (1961); (b) F. H. Westheimer, *Acc. Chem. Res.*, **1**, 70 (1968).

(28) F. Ramirez, O. P. Madan, N. B. Desai, S. Meyerson, and E. M. Banas, *J. Am. Chem. Soc.*, **85**, 2681 (1963).

(29) F. Ramirez, J. F. Marecek, and H. Okazaki, *J. Am. Chem. Soc.*, **98**, 5310 (1976).

(30) F. Ramirez, J. F. Marecek, H. Tsuboi, and H. Okazaki, *J. Org. Chem.*, **42**, 771 (1977).

(31) (a) F. Ramirez and J. F. Marecek, *Tetrahedron Lett.*, 3791 (1976); (b) F. Ramirez and J. F. Marecek, *ibid.*, 967 (1977).

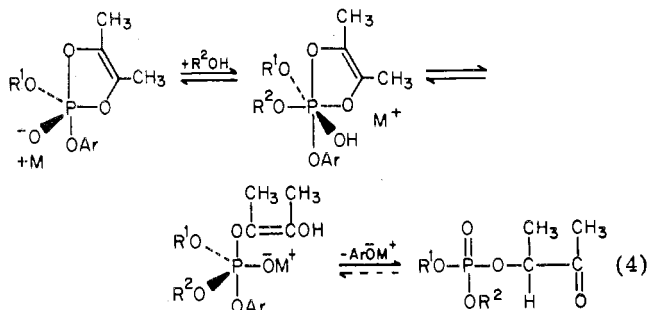

+ R²OH → P(6) is rate limiting and that the collapse of P(6) is accompanied by ring opening, which accounts for the effect of the catalyst on product composition as well as on reaction rate.

Preparation of CEP-X Reagents. A CEP-X reagent is defined as any derivative of the CEP family which undergoes substitutions at phosphorus with virtually complete ring retention (cf. eq 3). The CEP group was first described in the literature as part of a triester function, CEP-OR, which is not a CEP-X reagent in the above sense.³²⁻³⁴

A convenient procedure³⁵ (Scheme II) for the preparation of three CEP-X reagents involves the salt 1'-methylpyridinium 2-oxido-4,5-dimethyl-1,3,2-dioxaphosphole 2-oxide, which is obtained in 75% overall yield from biacetyl in two laboratory operations. The salt leads to bis(1,2-dimethylethenylene) pyrophosphate (CEPOCEP) in 90-95% yield upon treatment with phosgene for a relatively short period of time. The same salt is converted into 1,2-dimethylethenylene phosphorochloridate (CEP-Cl) in 88% yield by using an excess of phosgene for a prolonged period. Either CEPOCEP or CEP-Cl is transformed into *N*-(1,2-dimethylethenylenedioxyphosphoryl)imidazole (CEP-IM) in 90-95% yield, upon reaction with imidazole. The structures of the CEP-X reagents rest on extensive physical data, including the X-ray analysis of the pyrophosphate.³⁶

A second method of preparation of CEP-Cl involves the reaction of CEP-IM with hydrogen chloride.³⁷ CEP-Cl has also been made in 42% yield from CEP-OC₂H₅ and phosphorus pentachloride.³⁸

Simple Phosphodiester from CEP-X Reagents. Systematic procedures have been developed for the application of these reagents to the syntheses of many phosphodiester, and experimental details will be found in the original publications.²⁹⁻³¹ Long-chain (C₁₂-C₁₈) saturated and unsaturated diesters as well as cyclic phosphates (eq 5)³⁹ have been made by these proce-

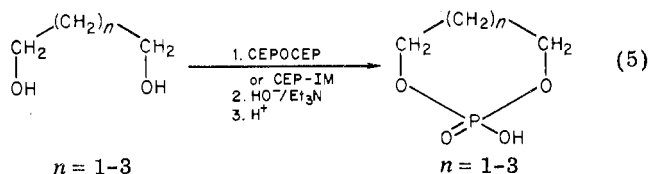

(32) F. Ramirez, O. P. Madan, and C. P. Smith, *J. Am. Chem. Soc.*, **87**, 670 (1965).

(33) V. A. Kukhtin and I. P. Gozman, *Dokl. Akad. Nauk SSSR*, **158**, 157 (1964).

(34) R. Ramirez, J. F. Marecek, S. L. Glaser, and P. Stern, *Phosphorus*, **4**, 65 (1974).

(35) F. Ramirez, H. Okazaki, J. F. Marecek, and H. Tsuboi, *Synthesis*, **819** (1976).

(36) J. S. Ricci, B. R. Davis, F. Ramirez, and J. F. Marecek, *J. Am. Chem. Soc.*, **97**, 5457 (1975).

(37) F. Ramirez, H. Okazaki, and J. F. Marecek, *Synthesis*, **637** (1975).

(38) I. P. Gozman, *Izv. Akad. Nauk SSSR*, 2362 (1968).

Scheme II

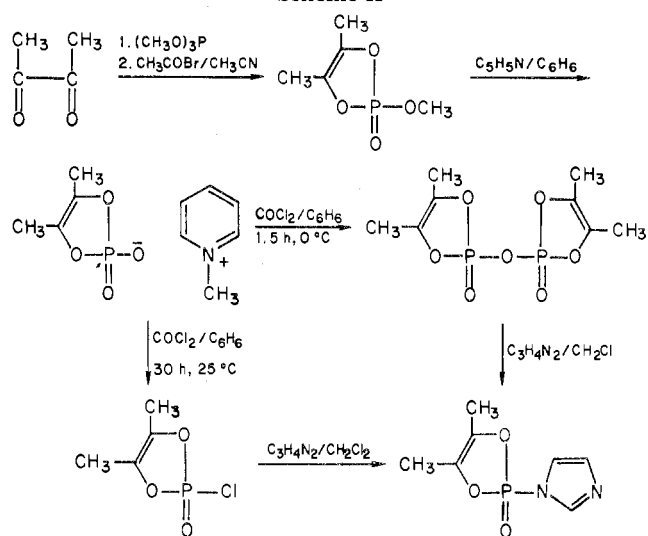

dures. Of particular interest are the analogues of adenosine 3',5'-cyclic phosphate⁴⁰ which become readily available using the anhydride, CEPOCEP, or CEP-IM.³⁹

When CEP-IM is used as reagent the catalyst is imidazole, since the latter is produced in the first step of the synthesis: CEP-IM + R¹OH → CEP-OR¹ + IMH. When CEPOCEP or CEP-Cl is employed, a strong acid is produced and hence 1 equiv of triethylamine is introduced with R¹OH to act as proton acceptor:

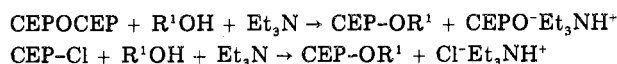

Additional amine is then added to act as catalyst for the second step. The salts formed from a relatively strong base, such as triethylamine, and the strong acid CEP-OH do not react appreciably with alcohols under the conditions of the syntheses. In contrast, the acid itself is quite reactive toward alcohols.

In all these syntheses, the crucial factor is that the first alcohol, R¹OH, reacts much faster with the reagent, CEP-X, than with the product, CEP-OR¹, and consequently no symmetrical triester, (R¹O)₂P(O)OAcn, is formed in this step.

Phosphodiester syntheses involving polyols usually require some protection of the remaining alcohol functions. Use has been made of the *tert*-butyldimethylsilyl protecting group which is quite stable toward base (eq 6). This group, as well as the phosphate blocking 3-oxo-2-butyl group, is also relatively stable toward acid and is not affected by conditions which remove other base-stable, acid-labile protecting groups such as (*p*-CH₃OC₆H₄)(C₆H₅)₂C. On the other hand, after the mildly basic deblocking step the silyl group becomes quite sensitive toward acid, to the point where addition of acid to slightly beyond the equivalence point suffices for deprotection.⁴¹ This phenomenon has been attributed to the high local acid concentration around

(39) (a) F. Ramirez, H. Tsuboi, H. Okazaki, and J. F. Marecek, unpublished work; (b) F. Ramirez, J. F. Marecek, and K. Cheng, *Phosphorus Sulfur*, **4**, 43 (1978).

(40) F. Ramirez, J. F. Marecek, I. Ugi, P. Lemmen, and D. Marquarding, *Phosphorus*, **5**, 73 (1975).

(41) F. Ramirez, P. V. Ioannou, J. F. Marecek, M. Nowakowski, B. T. Golding, and G. H. Dodd, *Synthesis*, 483 (1976).

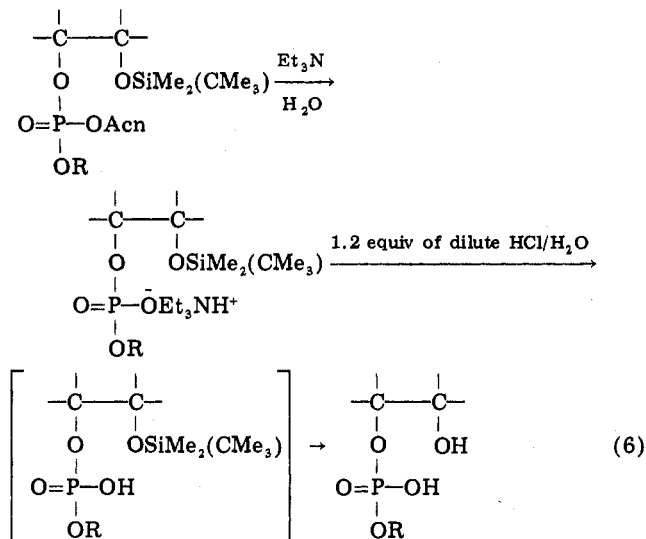

the phosphate function which results in a neighboring group participation of the silyloxy function.

Synthesis of Deoxyribooligonucleotides. The pyrophosphate, CEPOCEP, is a satisfactory reagent for the establishment of the 3'→5'-internucleotide bond in 2'-deoxythymidine (T). The *p*-methoxytrityl group is used to protect the C-5' hydroxyl function of the *first* molecule of T in the synthesis of the dinucleotide, TpT (Scheme III). No protection of the C3' OH function is used at any stage. The procedure is "two step" since the cyclic triester is not isolated. The acyclic 5'-protected triester is obtained in 82% overall yield based on protected T, after silica gel chromatography. Deprotection is achieved with a few mole equivalents of CF₃COOH in 0.002 M CH₂Cl₂ solution at 0 °C and yields the corresponding triester in 90% yield after silica gel chromatography. The deblocking step is extremely rapid relative to simpler triesters, and the desired dinucleotide is isolated as its salt, TpT·Et₃NH⁺·3H₂O, in 85% yield, after anion-exchange chromatography.⁴²

The synthesis of a tetranucleotide by the same procedure has also been carried out (Scheme IV). The yields of the protected tri- and tetranucleotide triesters drop to 61 and 49%, respectively. This phenomenon has already been noted in other oligonucleotide syntheses, and is probably due to increasing difficulty in removing tightly bound water from the larger triesters and increasing inaccessibility of the C3' OH function to the CEPOCEP reagent and of the corresponding cyclic phosphate to the C5' OH of the incoming T. The deprotection of the tetranucleotide triester remains satisfactory (82% yield of product after purification). The tetranucleotide is isolated as the salt, TpTpTpT³⁻·3Et₃NH⁺·7H₂O, in 75% yield after the usual deblocking and purification step.⁴²

The above sequence of alcohol deprotection and phosphate deblocking (cf. Scheme III) can be reversed, and this technique provides oligonucleotide triethylammonium salts with terminal C5' OR protection. These salts are attractive precursors for the synthesis⁴³

(42) F. Ramirez, E. Evangelidou-Tsolis, A. Jankowski, and J. F. Marecek, *J. Org. Chem.*, **42**, 3144 (1977).

(43) (a) F. Ramirez, R. Sarma, Y. F. Chaw, T. McCaffrey, J. F. Marecek, B. McKeever, and D. Niernan, *J. Am. Chem. Soc.*, **99**, 5285 (1977); (b) P. Narayanan, F. Ramirez, T. McCaffrey, Y. F. Chaw, and J. F. Marecek, *J. Org. Chem.*, **43**, 24 (1978).

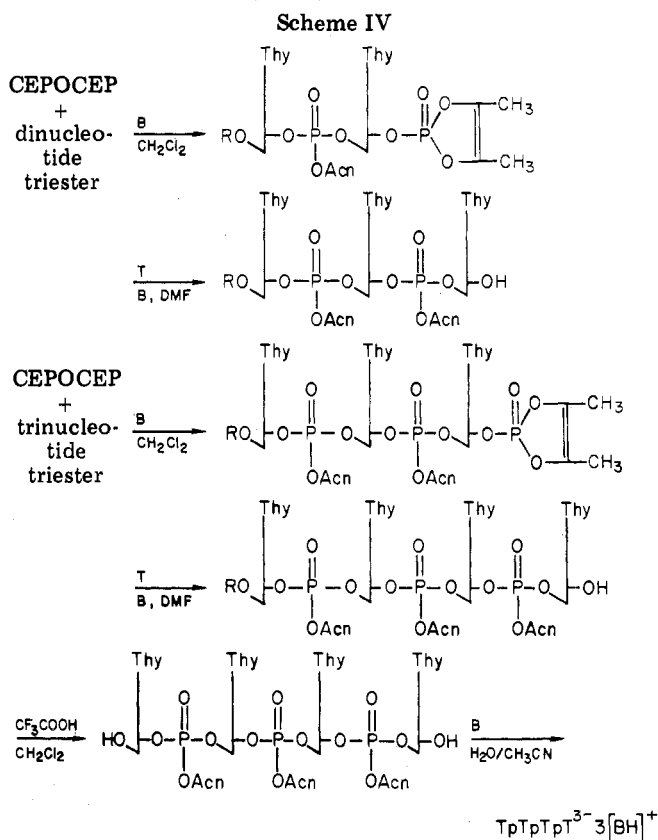
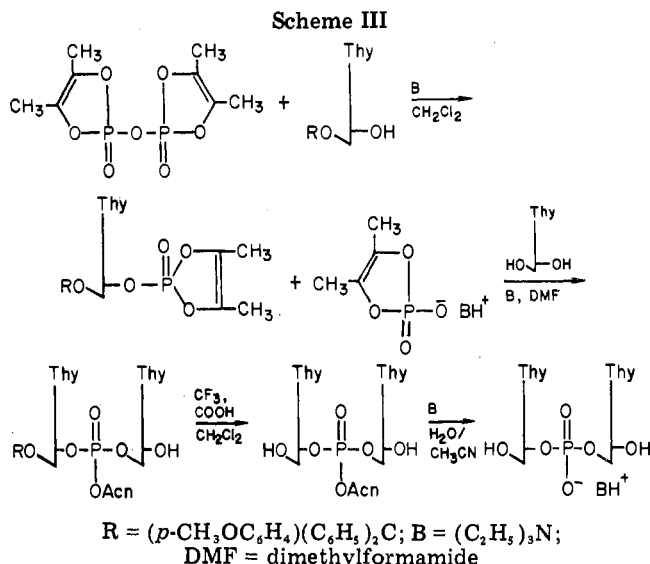

of anhydrous and partially hydrated magnesium polynucleotide complexes of the type that may be involved in transfer RNA tertiary structure.⁴⁴

Synthesis of Phospholipids. The properties of biological membranes are partly determined by the charge distribution of their phospholipid components, which, in turn, depends on the structure of the polar head group, including the R^H moiety (cf. Chart I).

One of the most interesting types of phospholipids from the point of view of charge distribution is *cardiolipin*⁴⁵ (2), which is found in prokaryotic and eukaryotic cells with only minor variations in the degree of un-

(44) A. Jack, J. E. Ladner, D. Rhodes, R. S. Brown, and A. Klug, *J. Mol. Biol.*, **111**, 315 (1977).

(45) F. Ramirez, P. V. Ioannou, J. F. Marecek, G. H. Dodd, and B. T. Golding, *Tetrahedron*, **33**, 599 (1977), and references therein.

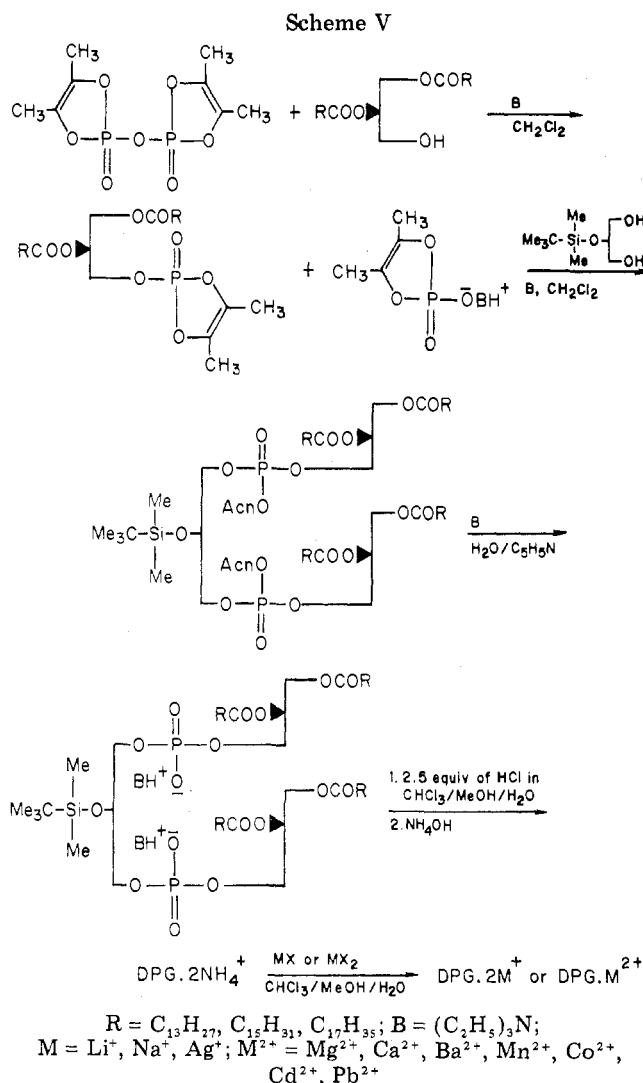

saturation of some fatty acid residues. In mammals, cardiolipin is found mainly in the heart and skeletal muscles, mostly in the inner membrane of the mitochondria. Cardiolipin is apparently absent from microsomes and nuclei of normal (but not of malignant) cells. Molecular models of cardiolipin suggest a relationship between the charge of the metal cation and the conformation of the molecule. Thus, a divalent cation can hold together both halves of the molecule and influence the shape of the molecule.

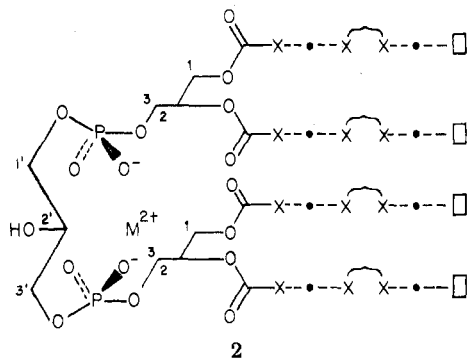

DPG·M²⁺ = 1',3'-diphosphatidylglycerol (cardiolipin); x = CH₂ above plane, • = CH₂ below plane, □ = CH₃

The synthesis of cardiolipin has been achieved⁴⁵ by means of a CEP-X reagent (Scheme V), and many salts

of mono- and divalent metal ions have become available for further study. The only intermediate isolated is the silyl-protected triester, which is purified by silicic acid chromatography. The pure intermediate is isolated in ca. 40% yield based on diglyceride, which is reasonably good considering that two successive phosphorylations must be carried out by the CEP-OR¹ initially produced. The first phosphorylation step is normal, in the sense that it is susceptible to triethylamine catalysis and involves little transesterification; however, the second step is faster than the first, even though it is not catalyzed by triethylamine. These complications presumably arise from powerful lipid-lipid interactions which alter the simpler solution kinetics of smaller substrates. The sequential removal of the phosphate block and the silyl group proceed quite smoothly, aided by the neighboring-group effect previously mentioned. The cardiolipin diammonium salt is purified by anion-exchange chromatography and is isolated in ca. 80% yield based on triester.

A second type of phospholipid has been synthesized⁴⁶ by means of CEPOCEP or CEP-Cl (eq 6a). The

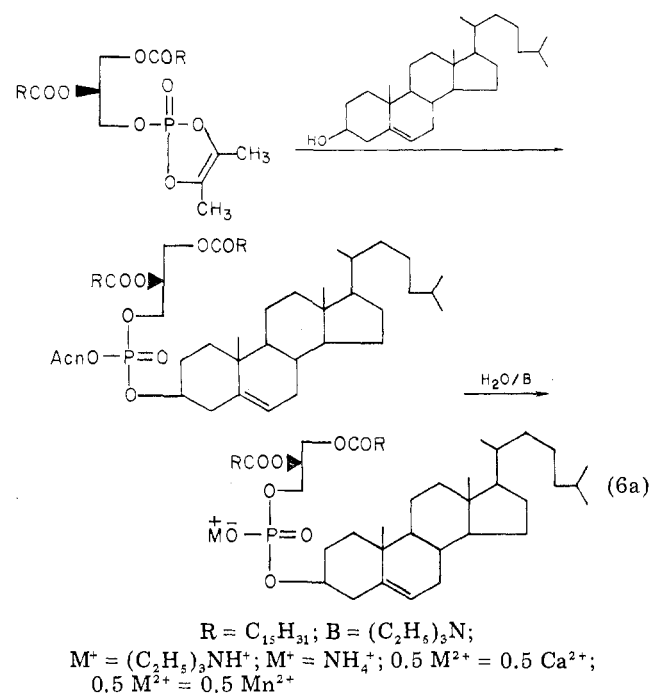

phospholiposteroids have not been implicated in the chemistry of natural lipids, but it is conceivable that they may actually occur in biological membranes. The coexistence of cholesterol and phospholipids in plasma membranes has prompted many studies of lipid-cholesterol interactions, but not when both components are covalently bonded to each other. There is evidence that cholesterol, somehow, influences the packing of phospholipid molecules and the permeability of model membranes made from them.

Model experiments⁴⁷ show that the CEP-X reagents can be used to incorporate the choline cation into the phosphodiester molecule. Choline is phosphorylated by a CEP-OR,¹ the resulting triester is submitted to the usual deblocking step, and the zwitterion is isolated as

(46) F. Ramirez, P. V. Ioannou, and J. F. Marecek, *Synthesis*, 673 (1977).

(47) F. Ramirez, H. Okazaki, and J. F. Marecek, unpublished.

a crystalline monohydrate (eq 7).

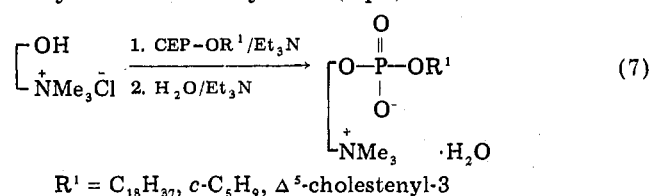

Conclusions

Our basic three-step synthesis of phosphodiester is a practical route to complex and sensitive compounds of the type needed in studies of some biochemical processes at the molecular level. The neighboring-group effect involving *tert*-butyldimethylsilyl and phosphodiester functions could be particularly useful in the synthesis of ribopolynucleotides, and hence in the construction of transfer RNA fragments.^{4e} In this approach, the first nucleoside of the chain needs protection at 2'-OH and 5'-OH, the internal nucleosides

require protection only at 2'-OH, and the last nucleoside of the sequence may not require protection at all, since the terminal 3'-OH is not phosphorylated.

This research has also provided glimpses into the complexity of phosphorylation mechanisms, in particular the power of nucleophilic catalysis and the importance of aprotic media of relatively low polarity. In this respect, the work has extended our knowledge of related phenomena in aqueous media. It is possible that the intermediacy of pentacoordinate and hexacoordinate phosphorus species may be an important characteristic of enzymatic phosphorylations. The striking effects of imidazole, triethylamine, phenoxide ion, and acetate ion in our experiments provide models for the possible behavior of histidine, lysine, arginine, tyrosine, aspartic acid, and glutamic acid residues in enzymatic reactions. These amino acid residues are known to be involved in many phosphoryl-transfer active sites.

Synthesis and Chemistry of Benzocyclopropenes

W. EDWARD BILLUPS

Department of Chemistry, Rice University, Houston, Texas 77001

Received March 2, 1977

Benzocyclopropene (1) and benzyne (2) constitute the



most highly strained members of the series of 1,2-bridged derivatives of benzene. Whereas benzyne is a transient species, detected only at low temperature using infrared spectroscopy of a matrix,¹ benzocyclopropene exhibits remarkable thermal stability despite the high strain energy associated with this ring system. In this Account, I will discuss some recent developments in benzocyclopropene chemistry, including synthesis and important physical and chemical properties of these fascinating hydrocarbons. The reader is referred to the excellent comprehensive review² by Halton in which earlier work in this field is described.

Synthesis

The first synthesis of a benzocyclopropene derivative was reported by Anet and Anet³ in 1964. They found that the 3*H*-indazole 3 underwent smooth elimination of molecular nitrogen upon photolysis with the formation of 4 in low yield along with methyl 4-isopropenylbenzoate (5). Closs⁴ utilized this route in the synthesis of several derivatives of benzocyclopropene

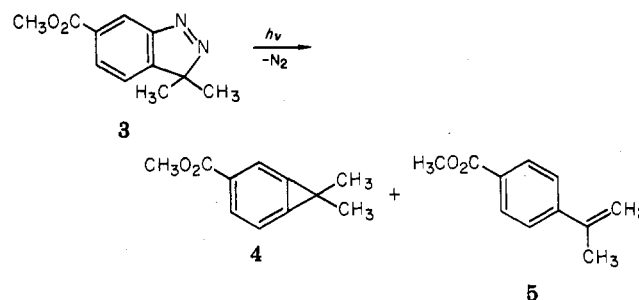

and has provided evidence for triplet diradical intermediates, although it is not clear whether they arise directly from the indazole or diazo compound 6. Since

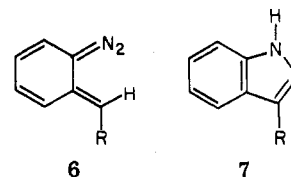

3-monosubstituted indazoles exist in the 1*H* form 7, this method is useful only for the synthesis of *gem*-disubstituted benzocyclopropenes.

Dürr and Schrader⁵ prepared 9, the first naphthocyclopropene, in 30% yield by irradiation of the

W. E. Billups is Associate Professor of Chemistry at Rice University. He received the B.S. degree from Marshall University in 1961. This was followed by a period in industry with the Union Carbide Corporation. In 1968 he entered the graduate school of The Pennsylvania State University and received the Ph.D. in 1970. He then joined the Chemistry Department at Rice University. His research interests are divided among the areas of small-ring compounds, reactive intermediates, and organotransition-metal chemistry.

(1) O. L. Chapman, K. Mattes, C. L. McIntosh, J. Pacansky, G. V. Calder, and G. Orr, *J. Am. Chem. Soc.*, **95**, 6134 (1973).
 (2) B. Halton, *Chem. Rev.*, **73**, 113 (1973).
 (3) R. Anet and F. A. L. Anet, *J. Am. Chem. Soc.*, **86**, 525 (1964).
 (4) G. L. Closs, *Adv. Alicycl. Chem.*, **1**, 53 (1966); G. L. Closs, L. R. Kaplan, and V. I. Bendall, *J. Am. Chem. Soc.*, **89**, 3376 (1967).
 (5) H. Dürr and L. Schrader, *Angew. Chem.*, **81**, 426 (1969); *Angew. Chem., Int. Ed. Engl.*, **8**, 446 (1969); *Chem. Ber.*, **103**, 1334 (1970).